

# BENDIX-SCINTILLA MAGNETOS

## BENDIX MAGNETO ENGINE APPLICATIONS

Make	Engine Model	Magneto Type	Magneto Replacement	Units per Engine
Continental	A-65-8, A-75-8,	S4RN-20	10-51360-27 (Rt. Side)	1
	C-75-8, C-85-8 with original crankcase	S4RN-21	10-51360-28 (S(Lt. Side)	1
	A65-8, A-75-8, C-75-8, C-85-8 with current crankcase castings No. 6794 & No. 6795	S4RN-21	10-51360-28	2
	C-75-12F, C-85-8F, C-85-12F, C-90-12,	S4LN-21	10-51360-26	2
	C-115, C-125-2, C-145-2, C-145-4	S6LN-21	10-51365-39	2
	E-165-2, E-185-2 (above S/N 10111) E-185-3, E-185-9 (above S/N 5937) (above S/N 20922), E-225-4, E-225-8 (all), O-470- (above S/N 5937)	S6LN-20	10-51365-43	2
	GO-300A, GO-300B	S6RN-21	10-51365-35	2
	O-470-2, -4, -13, -A, -B, -E, -G, -J, -K, -L, -M, BGSO-526-A	S6RN-25	10-79020-8	2
	O-470-13A	S6LN-23	10-52350-20	2
	PE-150-2, -6 Packette	S6LN-23	10-52350-20	1
FSO-526-A	S6RN-26	10-85290-2	2	
Franklin	6A4-150-B3, 6A4-165-B3	S6RN-21		2
	6V4-178-B3, -B33, O-335-2, -3	S6RN-21	10-51365-48	2

Make	Engine Model	Magneto Type	Magneto Replacement	Units per Engine	
Franklin	6V4-200-C32, -C33, O-335-2, -3, -5, -6	S6RN-23	10-52350-19	2	
	6A4-200-C6	S6RN-23	10-52350-21	2	
Lycoming	††O-145-B2, -B3, -C2, -C3, ††O-235-C,	S4LN-20	10-51360-29	1	
	O-235-C1, -C1A,	S4LN-21	10-51360-30	1	
	O-320-A1A, -A2A, -B1A, -B2A, O-340-A, -A1A,	S4LN-21	10-51360-30 (25° Lag) or	2	
	-A2A, -B1A, B2A, O-360-A, -A1A, -A1B, -B1A, -B2A	S4LN-21	10-51360-25 (35° Lag)	2	
	O-290-G (single ignition)	S4LN-21	10-51360-25	1	
	GO-435-C2, -C2A, -C2B, -C2B2, -C2C, -C2E, GO-480, -B, -B1A6, -B1C,	S6LN-20	10-51365-31	1	
	-B1D, -C1A, -C1D6, -C2E6, -F1A6, -F2A6, -F3A6, -F4A6	S6LN-21	10-51360-32	1	
	O-435-19, -20, VO-435A, -A1A, -A1B, -A1C, -A1D, GO-480-C1B6, -D1A,	S6LN-20	10-51365-33	1	
	-G1B6, GSO-480-A1A6, -A1C6, -B 1A6, -B1B6, -B1C6	S6LN-21	10-51365-34	1	
	O-435-6, -6A, -23, -23A,	S6LN-22	10-52350-22	1	
	-23B, -A1C (optional), O-480-1	S6LN-23	10-52350-23	1	
	O-435-17, GO-435-C2, -C2A, -C2B, -C2D,	S6LN-20	10-51365-44	1	
	GO-480-B1, -B1B, -C2C6, -F3B6, -F4B6	S6LN-21	10-51365-45	1	
	O-540		S6LN-20	10-51365-46	1
			S6LN-21	10-51365-47	1

\*See Listing Below.

\*\*New P/N 10-357584. \*\*\*New P/N 10-357586.

## PARTS COMMON TO S4N & S6N MAGNETOS

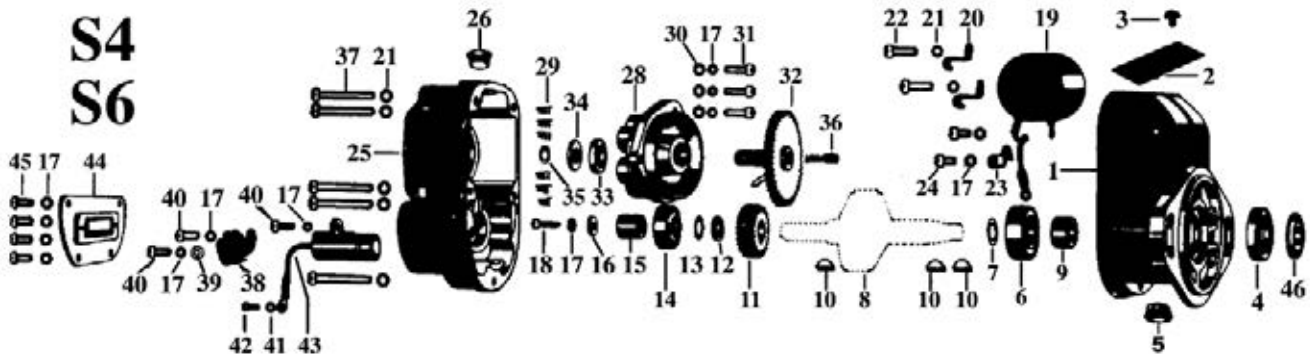

Ref. No.	Part No.	Description	Price Ea.
1	10-50727Y	Housing - Magneto	---
2	10-400012	Plate - Mag Ident	---
3	10-22067	Drive Screw - Ident Plate	---
4	10-357592	Oil Seal - Drive Shaft	---
5	10-157134	Vent - Mag Housing	---
6	10-81806	Bearing - Mag, Drive End	---
7	2-161-1	Shim Washer - .0025"	---
	2-161-2	Shim Washer - .004"	---
	2-161-3	Shim Washer - .005"	---
	2-161-4	Shim Washer - .008"	---
	2-161-5	Shim Washer - .010"	---
	2-161-6	Shim Washer - .012"	---
	---	(Drive End Bearing)	---
8	---	Magnet - Rotating	---
9	10-25788	Bushing - Drive Shaft	---
10	10-90788-5	Key - Woodruff	---
11	10-157123Y	Gear-Distrib., Small (S4)	---
11A	10-157120Y	Gear-Distrib., Small (S6)	---
12	10-3503	Spacer-Brkr End Bearing	---
13	2-199-1	Shim Washer - .002"	---
	2-199-2	Shim Washer - .004"	---

Ref. No.	Part No.	Description	Price Ea.
13	2-199-3	Shim Washer - .005"	---
	2-199-4	Shim Washer - .008"	---
	2-199-5	Shim Washer - .010"	---
	2-199-6	Shim Washer - .012"	---
	---	(Breaker End Bearing)	---
14	2-202	Bearing-Magnet, Brkr End	---
15	10-88543-1	Cam - Breaker	---
16	10-51354	Washer-Plain (Cam Screw)	---
18	10-35936-10	Screw - Cam	---
19	10-357164	Coil	---
20	10-50765	Clamp - Coil Core	---
21	---	Washer - Lock	---
22	10-35937-8	Screw - Coil Core Clamp	---
23	10-5752	Clip - Primary Lead	---
24	10-16479	Screw	---
25	---	Housing - Distributor	---
26	10-157135	Plug - Distributor Housing	---
27	---	Bushing - Ground Terminal	---
28	10-52949	Block - Distributor (S4)	---
28A	10-52958	Block - Distributor (S6)	---
29	10-50737	Spring-H.T. Cable Contact	---

Ref. No.	Part No.	Description	Price Ea.
30	---	Washer - Plain	---
31	---	Screw - Distributor Block	---
32	10-357584	Gear-Distributor, Large (S4)**	---
32A	10-357586	Gear-Distributor, Large (S6)***	---
33	10-50752	Washer - Felt	---
35	10-92815-37	Ring-Retain. (Distributor, Gear)	---
36	10-9595	Brush - Carbon	---
37	10-157158	Screw	---
38	---	Breaker Assembly*	---
39	10-14268	Washer - Plain	---
40	10-157161	Screw	---
41	---	Washer - Lock	---
42	---	Screw - Lead to Breaker	---
43	10-51676	Condenser	---
44	---	Cover - Breaker	---
45	10-157161	Screw - Breaker Cover	---
46	10-51678	Oil Slinger - Drive Shaft	---