



AIRCRAFT TOOL SUPPLY COMPANY

1000 Old U.S. 23, Oscoda, MI 48750 • 1-800-248-0638 • www.aircraft-tool.com

ATS PRO BEADING TOOL KIT

(Model AP145)

- New Parker-Style Beading Kit
- Meets MILSPEC MS33660D and SAE AS5131 specifications.
- Beads aluminum, copper, brass and mild steel tubes.
- Diameters: 1/4", 3/8", 1/2", 5/8", 3/4", and 1"
- Includes plastic storage case



Thank you for purchasing the ATS Pro Beading Kit – The finest beading tool on the market today. Your ATS Pro Beading Kit fully meets MILSPEC MS33660D (Aviation and Aerospace), and SAE AS5131 Types A & B (Aerospace) standards. When used properly, Your ATS Pro Beading Kit will consistently produce flawless beads in aluminum, brass, copper, and mild steel tubing in sizes ranging from 1/4" to 1". Please read the following instructions to ensure that you get the best results from your ATS Pro Beading Kit.

INSTRUCTIONS

Select a frame having the correct outside rollers for the size of tube to be beaded. The frame with the small rollers is used with the #4 die; the medium roller frame is for the #6, #8, and #10 dies; and the frame with the large rollers works with the #12 and #16 dies (*see table below for selection guide*).



Figure 1

Slide the bushing into position in the frame and pull the release knob to seat the bushing into place (figure 1), making sure that the hole in the bushing lines up with the release knob's holding pin. When the bushing is properly lined up it should seat squarely on the frame, and the release knob should snap back into place (figure 2). *Note: A bushing is not required for the #4 die, as it is designed to fit directly into the frame.*



Figure 2

Select the proper size die and insert it into the bushing. Seat the die by pulling on the release knob until the die seats itself into the bushing. The die is properly seated when it rests squarely on the top surface of the bushing, and the holding pin passes through the groove in the die (figure 3). The die should rotate freely and smoothly inside the bushing.



Figure 3

Clamp the tube between the rubber blocks in the Tube Holder a few inches from the end of the tube (figure 4). Apply just enough pressure to prevent the tube from spinning when forming the bead. Take care not to over-tighten the clamp, as this may deform the tube.



Figure 4

Lubricate inside and outside of the tube with medium oil for ½” from end, and remove the excess oil. Next, slide the tube over the beading die until it touches face of the bushing and tighten the beading assembly until the rollers just engage the tube wall.



Figure 5

Holding the Tube Holder in the left hand, rotate the Beading Tool counterclockwise with the right hand while occasionally adjusting the roller screw downward slightly to maintain pressure (figure 5).

Form the bead slowly and deliberately – do not try to rush it. Start out by applying just enough pressure to start deforming the tube and establish a track. This will prevent the tube from spinning off the die as you form the bead. Next, apply a bit more pressure and rotate the Beading Tool a few more times until you feel the resistance let up (figure 6). Continue like this until you arrive at the correct bead diameter (see table below).



Figure 6

Inspect your work. A properly formed bead should be clean and free of nicks, scrapes, or fractures. The beading process itself may leave roller lines on the tube, which is easily buffed off if necessary. Also, the slight flare raised on the end of the tube while beading #4 (1/4”) tubing should be removed with a fine tooth file (figure 7).



Figure 7

CAUTION – do not attempt to bead steel using the #4 (1/4”) die.

If many similar beads are to be made, lock the stop nuts on the adjusting screw when the correct diameter bead is reached. Set the locknuts against the frame at the completion of a bead. The nuts will then stop further beading action at the proper place.

BEADING TIPS

1. Don't forget to use oil... You cannot make a good bead without proper lubrication.
2. Be sure the tube end is cut off squarely and all burrs are removed.
3. The rubber blocks of the Tube Holder, and the tube at the place where the holder will grip, should be clean and free from oil and grease film.
4. Be sure to use the proper size inner and outer rolls for the tube being beaded (see table below).
5. Place the Tube Holder as close as possible to the Bearer, allowing only sufficient working clearance between tools.
6. Start the bead slowly. Revolve the Beading Tool several times on the tube, applying little pressure in order to form a light groove or track to guide the grooving rolls. This will prevent the tool working off the tube as the bead is formed.
7. Form the bead slowly, or the tube may be distorted. Best results are obtained by a fairly rapid turning of the beading tool, with a very gradual tightening down of the grooving rolls.
8. If the tube end is out of round, bring it back to shape by adjusting the proper size beading tool so the inside roll just touches the low spots when the tool is revolved. Grasp the Beading Tool by the frame, tighten the rollers slightly and iron out the low spots.

BEADING SPECIFICATIONS

The following table defines the appropriate dies to use, and the correct bead diameters to comply with MILSPEC MS33660D and SAE AS5131 (Types A & B) specifications.

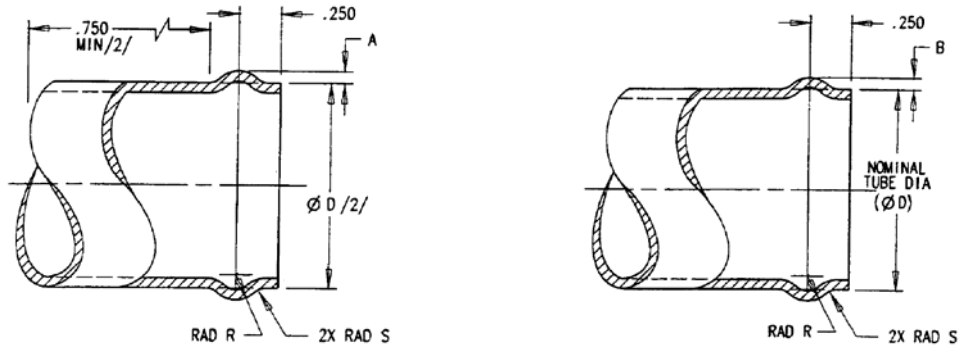

Tube Size (AS5131)	Nominal Diameter	MS33660D & SAE Type A Bead Size (A)	SAE Type B Bead Size (B)	Beading Die	Roller Size
04	.250"	.031"	.023" - .033"	#4	Small
06	.375"	.035"	.025" - .035"	#6	Medium
08	.500"	.038"	.028" - .038"	#8	Medium
10	.625"	.038"	.028" - .038"	#10	Medium
12	.750"	.038"	.030" - .040"	#12	Large
16	1.000"	.062"	.047" - .059"	#16	Large

BEADING KIT CONTENTS

Your ATS Pro Beading Tool Kit contains the items listed in the table below.

Part Number	Description	Quantity
12-342-7-2	Outside Rollers and Frame Assembly (Small)	1
12-342-16	#4 Beading Die (1/4")	1
12-342-7-3	Outside Rollers and Frame Assembly (Medium)	1
12-342-20-6	#6 Beading Die (3/8")	1
12-342-20-8	#8 Beading Die (1/2")	1
12-342-20-10	#10 Beading Die (5/8")	1
12-342-7-4	Outside Rollers and Frame Assembly (Large)	1
12-342-20-12	#12 Beading Die (3/4")	1
12-342-20-16	#16 Beading Die (1")	1
12-342-24	Tube Holder and Rubber Block Assembly	1
12-342-17	Bushing	2
4-444-2	Tool Box	1

A product of Aircraft Tool Supply Company.

AIRCRAFT TOOL SUPPLY COMPANY

P.O. Box 370 • 1000 Old U.S. 23 • Oscoda, Michigan 48750
 Tel: 1-800-248-0638 • Fax: (989) 739-1448 • www.aircraft-tool.com