

Installation Manual and Operating Instructions

# TRUE BLUE POWER

## TA360 SERIES

USB POWER DELIVERY  
CHARGING PORT

Manual Number  
9019411



Revision D • August 25, 2022

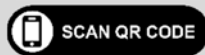
## **FOREWORD**

This manual provides information intended for use by persons who, in accordance with current regulatory requirements, are qualified to install this equipment. If further information is required, please contact:

True Blue Power  
c/o Mid-Continent Instrument Co., Inc.  
Attn: Customer Service Dept.  
9400 E. 34th St. N.  
Wichita, KS 67226 USA  
Phone 316-630-0101  
Fax 316-630-0723  
[www.truebluepowerusa.com](http://www.truebluepowerusa.com)  
[www.mcico.com](http://www.mcico.com)

We welcome your comments concerning this manual. Although every effort has been made to keep it free of errors, some may occur. When reporting a specific problem, please describe it briefly and include the manual part number, the paragraph/figure/table number and the page number. Send your comments to:

True Blue Power  
c/o Mid-Continent Instrument Co., Inc.  
Attn: Technical Publications  
9400 E. 34<sup>th</sup> St. N.  
Wichita, KS 67226 USA  
Phone 316-630-0101  
Fax 316-630-0723



Download the current version of this installation manual using your smartphone or tablet.

© Copyright 2019  
Mid-Continent Instrument Co., Inc.

**TABLE OF CONTENTS**

<b><u>SECTION 1</u></b>	<b><u>GENERAL DESCRIPTION</u></b>	<b><u>4</u></b>
1.1	INTRODUCTION	4
1.2	TECHNICAL SPECIFICATIONS	5
<b><u>SECTION 2</u></b>	<b><u>PRE-INSTALLATION</u></b>	<b><u>6</u></b>
2.1	COOLING	6
2.2	EQUIPMENT LOCATION	6
2.3	ROUTING OF CABLES	6
2.4	LIMITATIONS	6
2.5	MODIFICATIONS	7
<b><u>SECTION 3</u></b>	<b><u>INSTALLATION</u></b>	<b><u>8</u></b>
3.1	GENERAL INFORMATION	8
3.2	UNPACKING AND INSPECTING EQUIPMENT	8
3.3	CABLE HARNESS	8
3.4	MOUNTING	10
3.5	INSTALLATION COMPLETION	10
<b><u>SECTION 4</u></b>	<b><u>OPERATION</u></b>	<b><u>15</u></b>
4.1	ELECTRICAL PERFORMANCE	15
4.2	PROTECTIVE FEATURES	15
<b><u>SECTION 5</u></b>	<b><u>CONFORMANCE</u></b>	<b><u>16</u></b>
5.1	INSTRUCTIONS FOR CONTINUED AIRWORTHINESS	16
5.2	ENVIRONMENTAL QUALIFICATION STATEMENT	16

**REVISION HISTORY**

<b>Rev</b>	<b>Date</b>	<b>Detail</b>	<b>Approved</b>
A	10/18/2019	Initial Release	BAW
B	05/14/2020	Updated style and brand to meet Marketing and Engineering guidelines. Update Section 3.2, Optional Equipment names. Update Wire Gauge values in section 3.3.1.	DLR
C	06/30/2020	Updated DO-160 qualifications in Section 5 based on additional testing. Updated wire length in Section 3.3.1.	DLR
D	08/25/2022	Updated document to include new 100W model. Aligned product name to match website.	ESH

## **SECTION 1 GENERAL DESCRIPTION**

### **1.1 INTRODUCTION**

The TA360 Series MAX Power USB Charging Port is a certified accessory that charges any electronic device that uses either a USB Type-A or USB Type-C charging connector.

The TA360 supports the latest version of the USB charging standard, known as USB Power Delivery (PD) version 2.0 and 3.0. This smart charger provides intelligent negotiation with the connected cable and device to supply variable voltage at up to 5 amps, allowing up to a total of 100 watts of charging power. This provides maximum charging speed to a wide variety of the latest electronic devices, including mobile phones, tablets - even laptops - and more. The TA360 can determine the maximum power the device can support and will charge the device at the maximum speed allowed, while preventing the device from being overcharged or charged incorrectly. The TA360 also incorporates True Blue Power's proprietary Cable-Drop Compensator which cancels the effect of voltage lost through the cable, extending the flexibility of cable/device combinations while maintaining the fastest charging possible.

The TA360 accepts an input of 22-32 volts DC from the aircraft and converts it to an output voltage from 5 to 20 volts DC, at a current up to 5 amps per port. The TA360 incorporates the latest USB Type-C connector to supply PD power, offering a smaller and reversible port connection, in either a single or dual port configuration. Additionally, a version is available that includes a traditional USB Type-A port combined with a USB PD Type-C port to support both legacy and newer cables and devices. Each version is available with or without lighting to conveniently locate the charging ports in low-light conditions. The unit has built-in protections for short circuit, over-current, and low voltage conditions. It is designed to protect against reverse polarity installation and has temperature monitoring and shutdown capability, allowing the unit to handle unforeseen conditions safely.

The TA360 is certified to FAA/TSO-C71 and qualified to multiple RTCA DO-160G environmental conditions for ease of installation and incorporation on any class or type of aircraft. The unit is easily mounted with two screws and a two-wire power input and can be installed throughout the aircraft, including the cockpit, cabin, galley, or other locations

Small, compact, powerful, and with plenty of installation flexibility, the TA360 is an ideal choice in any aircraft to charge the latest electronic devices at maximum speed.

## 1.2 TECHNICAL SPECIFICATIONS

<b>Electrical Attributes</b>	
Input Voltage	22-32 VDC
Input Power	135 watts max; 4.8 amps @ 28 VDC
Output Voltage	Auto-adjustable:5VDC, 9VDC, 15VDC, 20VDC per port
Output Power	5.0 amps max per port
Efficiency	~90% nominal

**Table 1.1**

<b>Physical Attributes</b>	
Weight	1.3 oz (28 g) (single Type-C port) 1.9 oz (51 g) (dual Type-A/Type-C port) 2.5 oz (60) (dual Type-C port)
Dimensions (Single Port Units) (not including mating connector)	1.50 inches wide X 0.52 inches high X 2.0 inches deep (38mm wide X 13mm high X 50mm deep)
Dimensions (Dual Port Units) (not including mating connector)	1.50 inches wide X 1.03 inches high X 2.0 inches deep (38mm wide X 26mm high X 50mm deep)
Charging Port Connector	USB Type-A or USB Type-C
Input Connector Kit	MCIA P/N 9017960
Mounting	Panel mount; rear

**Table 1.2**

<b>Qualifications</b>	
Certification:	FAA/TSO-C71
Environmental Qualification:	RTCA/DO-160G (See Section 5 for Categories/Levels)
USB Power Delivery (PD)	Version 2.0 and Version 3.0

**Table 1.3**

<b>Configurations</b>					
<b>Part Numbers</b>	<b>Non-Lighted</b>	<b>Lighted</b>	<b>USB Connector</b>		<b>Power (W)</b>
	6430360-1	6430360-11	Dual:	Type A +Type C	15 + 60
	6430360-3	6430360-13	Dual:	Type C +Type C	60 + 60
	6430360-7	6430360-17	Single:	Type C	60
	6430360-21	6430360-31	Dual:	Type A +Type C	15 + 100
	6430360-27	6430360-37	Single:	Type C	100

**Table 1.4**

## **SECTION 2 PRE-INSTALLATION**

### **2.1 COOLING**

No external cooling is required. The unit will become warm when in use. This is normal and within operational parameters. No special mounting considerations are required; however, mounting to a metal surface can help dissipate any heat generated and extend the life of the product. For the 100W versions, mounting to a metal surface or other thermal management approach is recommended. If a metal surface is unavailable, installing the unit in a location with air movement would be one such thermal management option.

### **2.2 EQUIPMENT LOCATION**

The TA360 Series MAX Power USB Charging Port is designed for mounting flexibility, allowing for installation in the cockpit or in the cabin. It is designed for panel mounting and can be installed in a rectangular configuration or, with an available installation kit, can be mounted with a round or rectangular cosmetic cover plate. An instrument mounting adapter bracket is also available to easily mount the unit in a standard 2-inch round instrument opening that may already exist in the cockpit panel.

The unit can be mounted in any orientation. Clearance should be provided for the mating connector which may require up to an additional inch beyond the rear of the unit.

### **2.3 ROUTING OF CABLES**

Avoid sharp bends in cabling and routing near aircraft control cables. Avoid close proximity and contact with aircraft structures, avionics equipment or other obstructions that could chafe wires during flight and cause undesirable effects.

### **2.4 LIMITATIONS**

Environmental qualifications were verified per RTCA DO-160, Revision G in lieu of those identified within the minimum performance standards (MPS) of the TSO.

The conditions and tests for TSO approval of this article are minimum performance standards. Those installing this article, on or in a specific type or class of aircraft, must determine that the aircraft installation conditions are within the TSO standards, specification of the article and deviations as listed above. TSO articles must have separate approval for installation in an aircraft. The article may be installed only according to 14 CFR part 43 or the applicable airworthiness requirements.

Installation recommendations provided in section 2.1. should be considered for 100W units when used in continuous operation under high-power conditions.



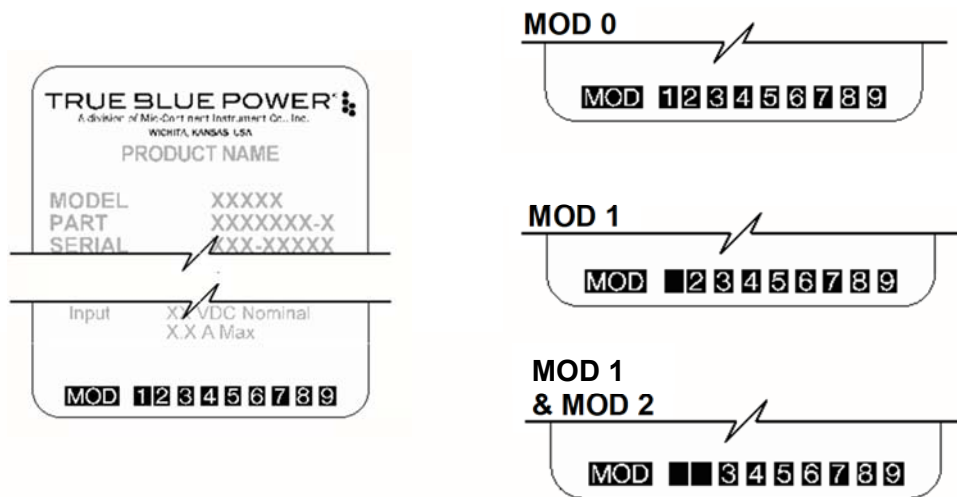
The USB PD is an extremely capable new technology for personal electronic devices. Beyond the physical format of the Type-C connector, it also allows for a variety of interface options when communicating with compatible devices. This device-to-charger communication is defined within the USB 3.1 Specification and Power Delivery standards. However, manufacturers of consumer electronic devices and/or cables may choose to implement proprietary versions or modifications of the USB standards to operate specifically with their own charging equipment. The TA360 has been tested with and supports a wide variety of devices now emerging on the open market. However, compatibility with all devices may not be guaranteed. True Blue Power continues to be proactive in evaluating new devices and strives to continually improve the product as needed to serve the vast majority of USB-charged electronic products.

## 2.5 MODIFICATIONS

This product has a nameplate that identifies the manufacturer, part number, description, certification(s) and technical specifications of the unit. It also includes the “MOD” or modification number representing notable changes in the hardware design of the unit.

Modification (MOD) 0 is the initial release of the product and is identified on the nameplate by the lack of marking on the MOD numbers 1 through 9 (i.e. 1-9 are visible). All subsequent modifications are identified on the nameplate by the marking/blacking out of that particular MOD number (i.e. for MOD 1, the number 1 is not visible and 2-9 are visible - see Figure 2.1 for examples). MODs do not have to be sequentially inclusive and may be applied independent of each other.

For additional details regarding specific changes associated with each MOD status refer to the product published Service Bulletins at [www.truebluepowerusa.com](http://www.truebluepowerusa.com).



**Figure 2.1**  
**Nameplate and MOD Status Example**



## SECTION 3 INSTALLATION

### 3.1 GENERAL INFORMATION

This section contains interconnect diagrams, mounting dimensions and other information pertaining to the installation of the TA360 Single and Dual USB Charger. After installation of cabling and before installation of the equipment, ensure that power and ground are applied to the proper pins specified in Section 3.3.2, Pin Assignment Information.

### 3.2 UNPACKING AND INSPECTING EQUIPMENT

When unpacking this equipment, make a visual inspection for evidence of any damage that may have occurred during shipment. The following parts should be included:

- |  |                      |
|--|----------------------|
| A. MAX Power USB Charging Port         | MCIA P/N 6430360-( ) |
| B. Installation Manual                 | MCIA P/N 9019411     |
| C. Connector Kit                       | MCIA P/N 9017960     |
| i. Mating Connector, 2-pin             |                      |
| ii. Pins (4) (2 required, 2 spares)    |                      |
| iii. Screws, #4-40 x 1/4 flat-head (2) |                      |
| iv. Screws, #4-40 x 5/16 flat-head (2) |                      |

Optional Equipment Available:

- |  |                    |
|--|--------------------|
| A. Dual Port Instrument Mount Adapter Kit    | MCIA P/N 9017947   |
| B. Single Port Rear Mount Faceplate Kit      | MCIA P/N 9019351-1 |
| C. Dual Port Rear Mount Faceplate Kit        | MCIA P/N 9017958   |
| D. Single Port Rear Mount Circular Faceplate | MCIA P/N 9019384-3 |
| E. Dual Port Rear Mount Circular Faceplate   | MCIA P/N 9019384-4 |

Equipment Not Provided:

- |                       |                                      |
|-----------------------|--------------------------------------|
| A. Cable Harness Wire | See Section 3.3.1 for specifications |
| B. Circuit Breaker    | See Table 3.2                        |

### 3.3 CABLE HARNESS

Construct the cable harness following the instructions outlined below and per Figure 3.1. Refer to Section 2: Pre-Installation Considerations, for routing precautions.

#### 3.3.1 Wire Gauge and Circuit Breaker Selection

Use of PTFE, ETFE, TFE, Teflon or Tefzel insulated wire is recommended for aircraft use. The wire harness should utilize 20-22 AWG stranded wire depending on model. Refer to table 3.1 below. This table is provided to aid in the consideration of voltage drop due to harness length. Any other wiring standards that are applicable to the installation should also be considered.

	Wire Gauge	Wire Length
60W units	20 AWG stranded wire	18 ft
	22 AWG stranded wire	11 ft
	24 AWG stranded wire	7 ft
100W units	20 AWG stranded wire	13 ft
	22 AWG stranded wire	8 ft

**Table 3.1**  
**Wire Gauge and Length**

Circuit breaker recommendations			
	Non-Lighted	Lighted	Breaker (Amps)
Part Numbers	6430360-1	6430360-11	5
	6430360-3	6430360-13	5
	6430360-7	6430360-17	5
	6430360-21	6430360-31	7
	6430360-27	6430360-37	7

**Table 3.2**  
**Circuit Breaker Recommendations**

### 3.3.2 Pin Assignment Information

INPUT POWER:

Pin A (keyed): +28VDC

Pin B: Ground

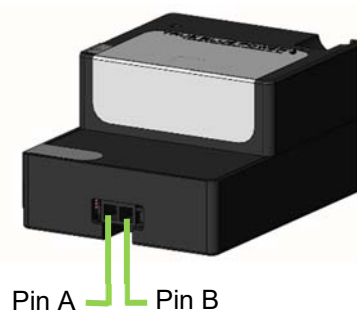
Note: Pins should be crimped using Molex Hand Crimp Tool 63819-0000 (Preferred), 63811-2800 (obsolete) or 11-01-0200 (obsolete). See the Molex Hand Crimp Tool User Manual for crimp procedures.

### 3.3.3 Harness Verification

Note:

The TA360 has built-in reverse polarity protection for the power connector. If Pins A and B are swapped, the unit will not function but will not be damaged.

Once the cable harness is prepared, prior to connecting the TA360, activate the aircraft power bus and use a multimeter to verify that aircraft power and ground is supplied with appropriate voltage on the proper pins within the mating harness.



**Figure 3.1**  
**Power Input**

### 3.4 MOUNTING

The TA360 can be installed in one of five ways:

- rear mount, rectangular
- instrument mount <sup>1 2 3</sup>
- rear mount, decorative faceplate <sup>1 4</sup>
- rear mount, circular faceplate <sup>1 3</sup>

- <sup>1</sup> Installation kit required. See Section 3.2, Optional Equipment Available for part number reference  
<sup>2</sup> Dual port units only  
<sup>3</sup> Black anodized  
<sup>4</sup> Brushed aluminum, bare (appropriate for additional plating/finish)

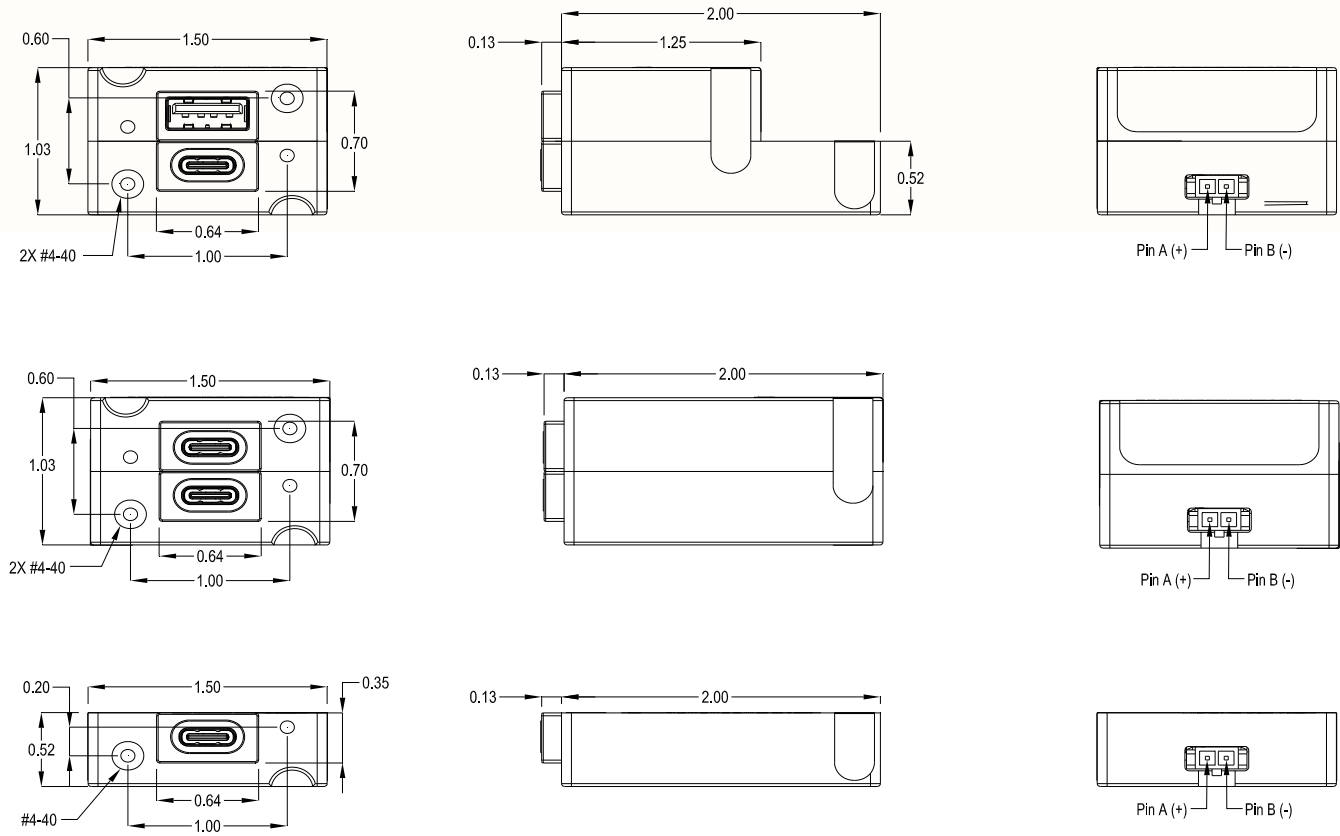
Prepare the panel cutout as shown in Figures 3.3 thru 3.9 per the selected mounting option.

- Countersinks shown in the panel cutouts for flat head screws are optional. However, flat head screws are provided for flush appearance. For Rear Mount Cover Plate Installations, countersinks in the panel are required.
- For Rear Mount Installations:  
 Mounting screws length MUST be between (PT +0.150”) and (PT +0.210”). [PT = panel thickness]  
 Mounting screws provided with the unit are 0.24” and 0.31”. (Accommodates 0.030” to 0.160” PT) For PT greater than 0.125, the USB connector will be below the surface of the panel (below flush).
- For Rear Mount Installation with Cover Plate: Panel thickness greater than 0.065 will cause the USB connector to be below the surface of the Cover Plate (below flush).

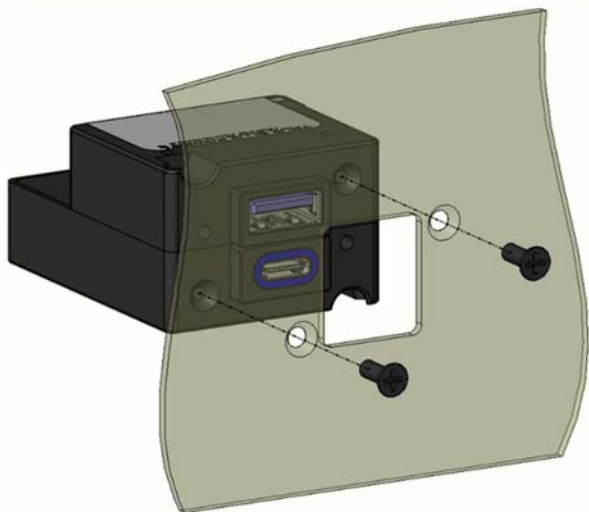
Note: When using 100W units under a continuous high-power load, installation recommendations provided in section 2.1. should be considered. Mounting the unit to a metal surface will greatly reduce the self-heating and help prevent thermal shutdown during extended high-power conditions. Without any thermal management, under worst case conditions, the exterior of the device can exceed 65°C. Under any conditions, should the temperature of the unit exceed its set threshold, it will safely shut down. (see section 4.2)

### 3.5 INSTALLATION COMPLETION

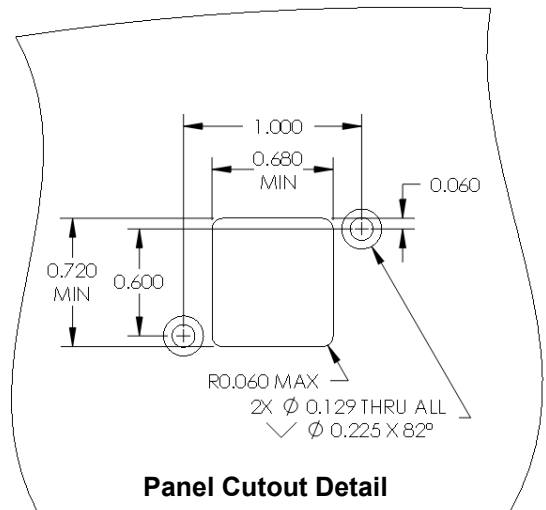
Prior to operating the unit in the aircraft, it is recommended to verify the output and functionality of the unit. In order to prevent accidental damage to other systems, it is not recommended to attach the output to other equipment prior to verification. Verify the output of the unit at the terminating end of the cable with a multimeter to ensure proper voltage and polarity. Once verified, installation can be completed, and functionality should be checked.



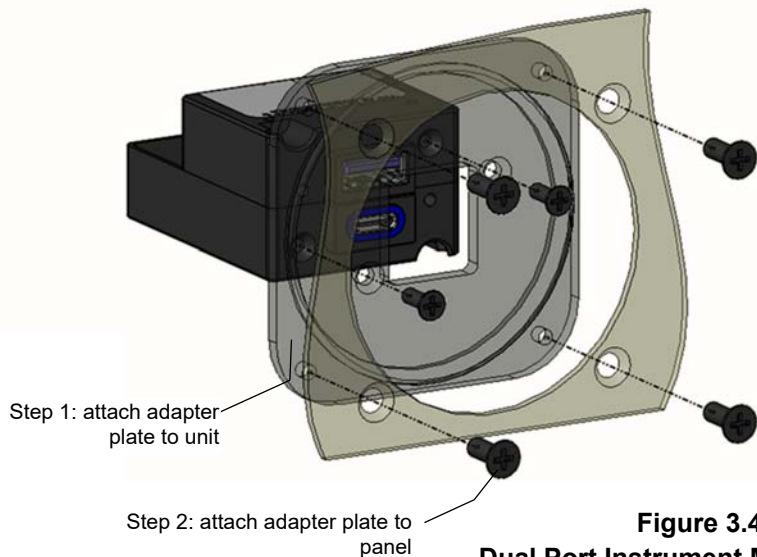
**Figure 3.2**  
**TA360 Outline Drawing**



**Figure 3.3**  
**Dual Port Rear Mount Installation**

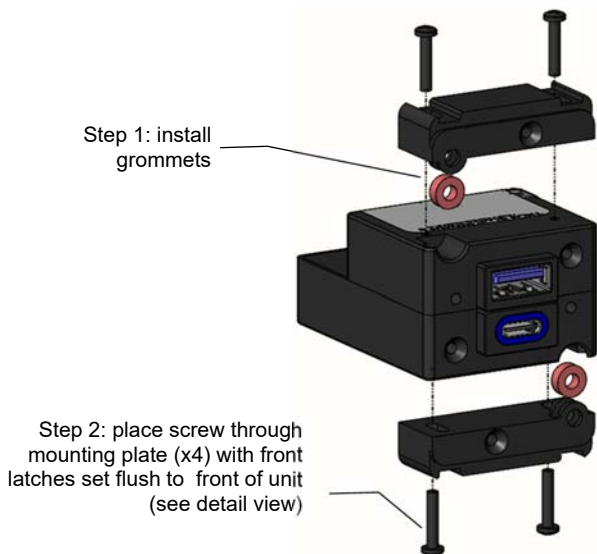


**Panel Cutout Detail**



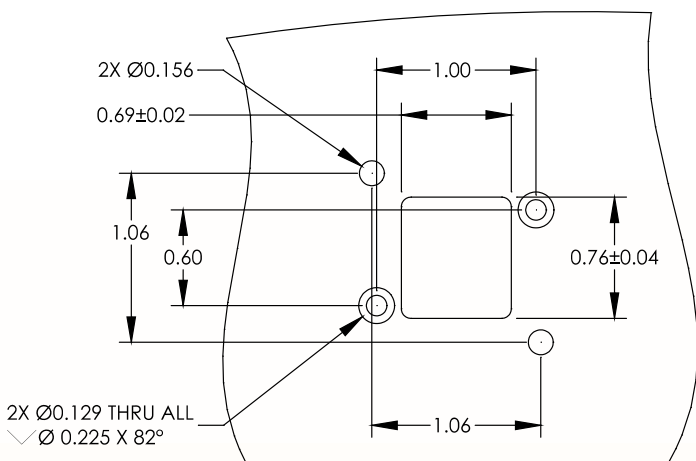
**Figure 3.4**

**Dual Port Instrument Mount Adapter Kit**



Latch and front of unit - flush

**Flush Detail**

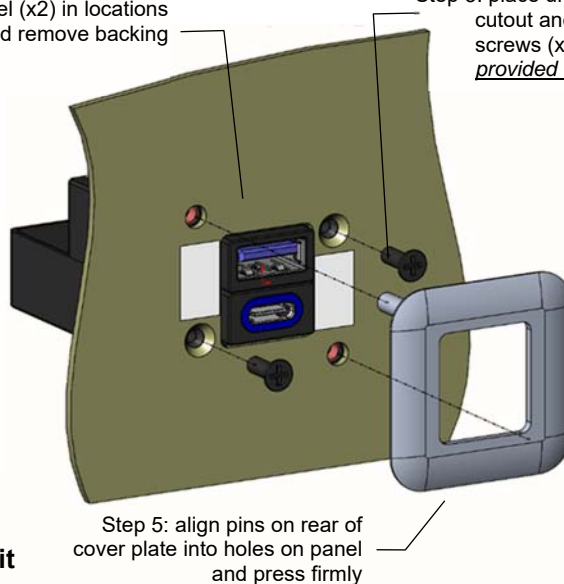


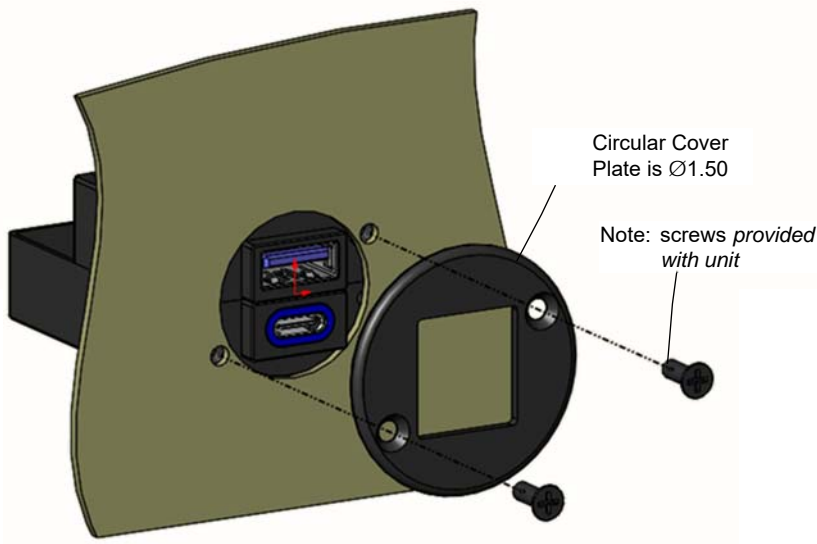
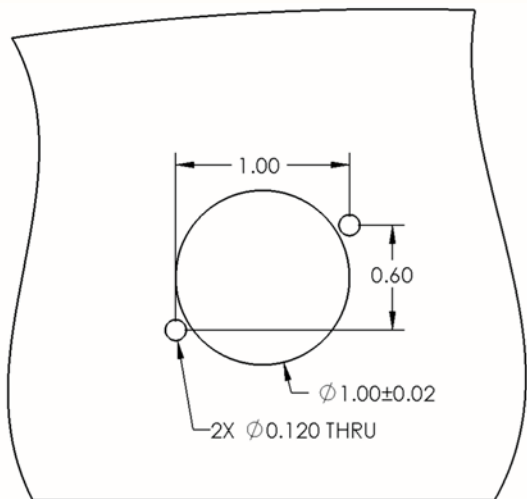
**Figure 3.5**

**Dual Port Rear Mount Faceplate Kit**

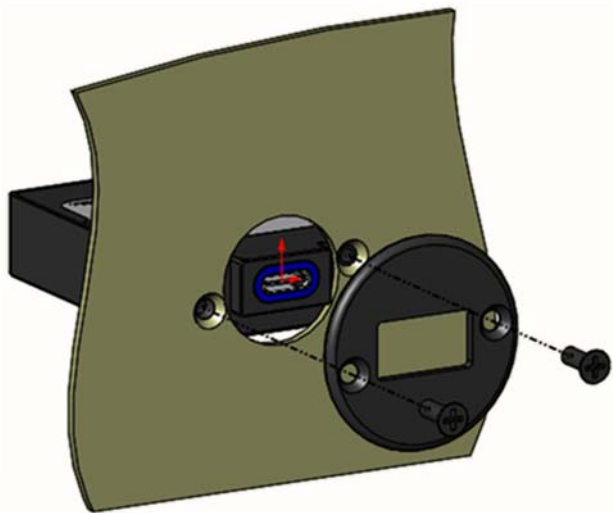
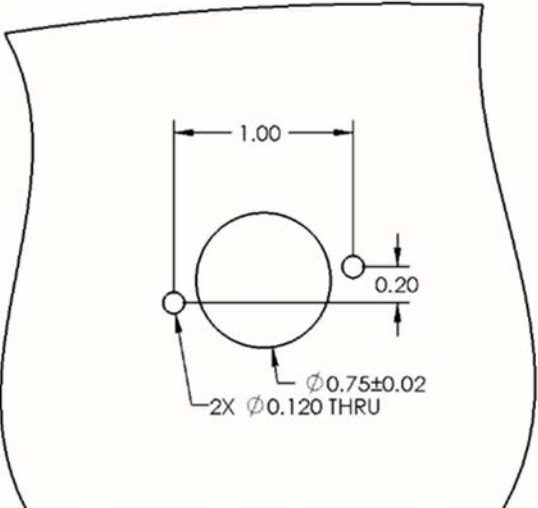
Step 4: place adhesive on panel (x2) in locations shown and remove backing

Step 3: place unit in panel cutout and secure with screws (x2) provided with unit



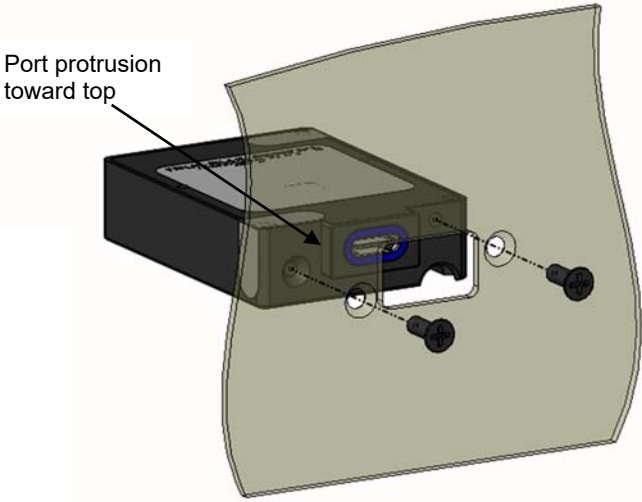
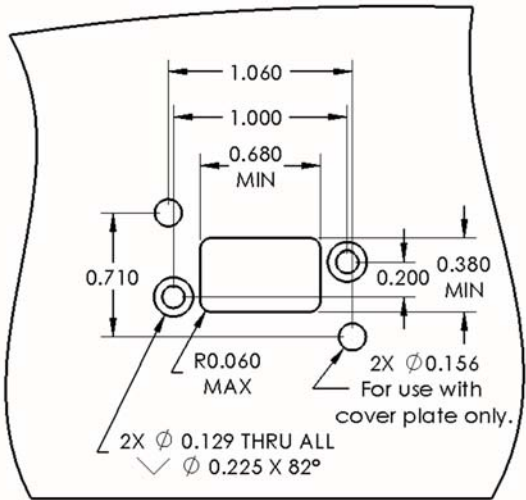


**Figure 3.6**  
**Dual Port Rear Mount Circular Faceplate**

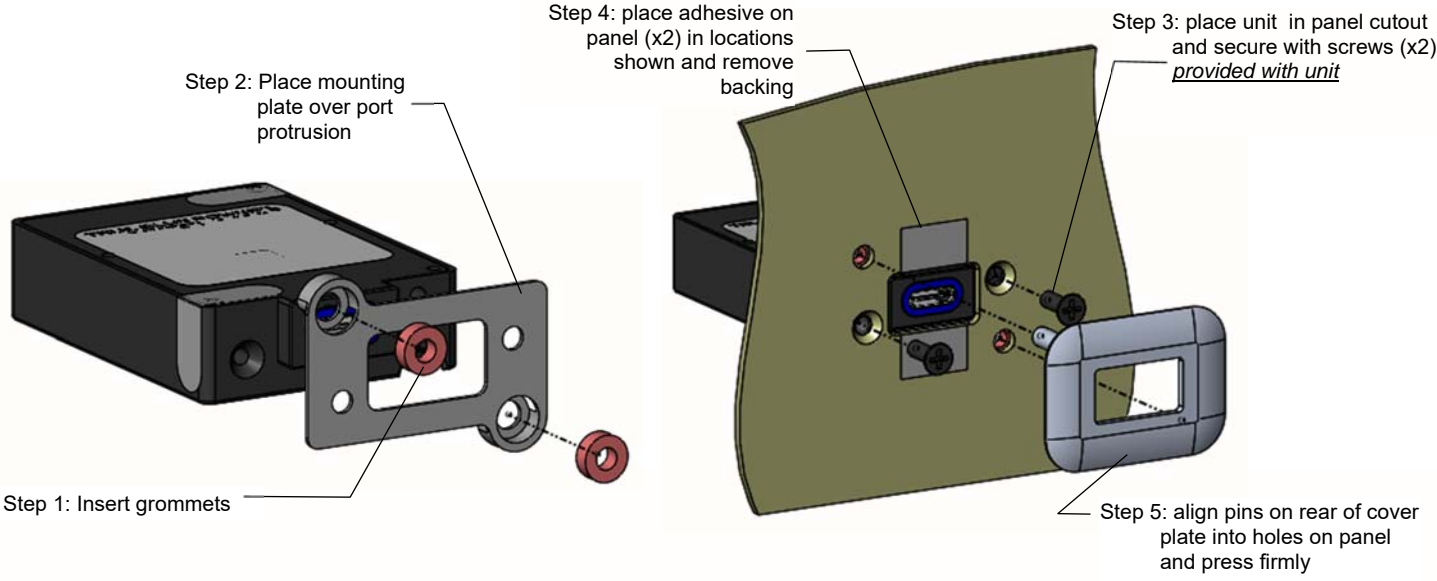


**Figure 3.7**  
**Single Port Rear Mount Circular Faceplate**





**Figure 3.8**  
**Single Port Rear Mount Installation**



**Figure 3.9**  
**Single Port Rear Mount Faceplate Kit**



## SECTION 4 OPERATION

### 4.1 ELECTRICAL PERFORMANCE

The TA360 Series MAX Power USB Charging Port converts a DC input voltage within the specified range to various output voltages, depending on the port type and device being charged. The Type A supplies 5V while the Type C ports intelligently negotiates with the device it is charging to provide either 5V, 9V, 15V or 20V. Type A ports provide up to 3 amps for 15 watts of power and Type C ports utilize the USB PD protocol to provide either 3 amps for up to 60 watts or 5 amps for up to 100 watts; depending on unit version. The TA360 will identify the maximum power that the attached device can receive and provide the fastest charge rate allowable.

(Note that per UL 1310, as a Class 2 power device, the TA360 is restricted to no more than 100 watts. Thus, per the over-voltage limit of USB PD, the 20V output is restricted to 4.65A at up to 21.5V)

The unit is designed as a DC-to-DC converter with a series switch on each output to regulate current applied to that output. Each series switch independently reduces the output current to a safe level if the USB portable device draws excess current, is shorted, or has a fault.

### 4.2 PROTECTIVE FEATURES

#### 4.2.1 Over-Current Protection

The TA360 monitors power individually on each port. During an over-current condition, the output power is disabled until the over-current condition is resolved with the connected device.

#### 4.2.2 Short Circuit Protection

The TA360 will survive a short circuit event without permanent damage. The unit disables output power as it would for over-current protection until the short is removed.

#### 4.2.3 Low Input Voltage Shutdown

If the input voltage applied to the TA360 drops below 22 VDC the unit will shut down until the applied voltage returns to a level within range.

#### 4.2.4 Over-Temperature

When the internal temperature of the TA360 exceeds designed thresholds, the unit will shut down and stop providing power. When the temperature returns to an acceptable level the unit will automatically begin providing power as requested.

#### 4.2.5 Reverse Polarity

The TA360 will protect itself against being installed with the input power wires reversed.

**SECTION 5 CONFORMANCE**

**5.1 INSTRUCTIONS FOR CONTINUED AIRWORTHINESS**

No periodic scheduled maintenance or calibration is necessary for continued airworthiness of the TA360 Series USB Power Delivery Charging Port. If the unit fails to perform to specifications, the unit must be removed and serviced by Mid-Continent Instruments and Avionics or their authorized designee.

**5.2 ENVIRONMENTAL QUALIFICATION STATEMENT**

**MODEL NUMBER:** TA360 Series      **PART NUMBER:** 6430360-( )  
**DESCRIPTION:** USB Power Delivery Charging Port      **CERTIFICATION:** FAA TSO-C71  
**MANUFACTURER:** True Blue Power, a division of Mid-Continent Instrument Co., Inc.  
**ADDRESS:** 9400 E. 34<sup>th</sup> St. North, Wichita, KS 67226, USA.  
**SPECIFICATION:** Test Specification (TS) 742 Test Data Sheet (TDS) 742  
**STANDARD:** RTCA DO-160, Rev G, dated 12/08/10; MIL-STD-810E, dated 7/14/1989

CONDITIONS	SECTION	DESCRIPTION OF TEST
Temperature and Altitude	4	Category F1
Temperature Variation	5	Category S2
Humidity	6	Category B
Operational Shock and Crash Safety	7	Category B
Vibration	8	DO-160: Category R; Curves C, C1 MIL-STD810E: See Remarks
Explosion	9	Category E
Waterproofness	10	Category W
Fluids	11	Category X
Sand and Dust	12	Category S
Fungus	13	Category F
Salt Spray	14	Category S
Magnetic Effect	15	Category Z
Power Input	16	Category B(XX)
Voltage Spike	17	Category B
Audio Frequency Conducted Susceptibility	18	Category R
Induced Signal Susceptibility	19	Category X
Radio Frequency Susceptibility	20	Category X
Emission of Radio Frequency Energy	21	Category H
Lightning Induced Transient Susceptibility	22	Category X
Lightning Direct Effects	23	Category X
Icing	24	Category X
ESD	25	Category A
Fire, Flammability	26	Category C

**REMARKS:**

Section 4: Category F1 with excursions as declared by the manufacturer:  
 • 4.6.2: Decompression +8,000 to 50,000 feet  
 Section 7: Crash Safety Impulse: 11ms, 40g Shock Wave  
 Section 8: Vibration per MIL-STD-810E: Sine-On-Random, Method 514.4, Cat. 4, Procedure 1