

Bus Manager Installation Instructions

Introduction

The Bus Manager was designed to provide a protected “essential power bus” for vehicles that rely upon critical electronic equipment for safe operation. This would include aircraft with electronic ignition or electronic fuel injection systems. The Bus Manager creates a protected 12 volt power source to ensure that these critical systems keep working during vehicle operation. The Bus Manager also includes a number of related functions to serve as a complete electrical distribution system.

Product Description

The Bus Manager system, when fully implemented manages a two battery vehicle power system plus additional emergency power circuit paths to provide triple redundant protection of essential bus powered systems. The basic functions of the Bus Manager are:

1. Provides triple redundant Essential Bus protection.
2. Built-in Essential Bus and Main Bus relays.
3. Simple key switch input to activate Busses.
4. Alternator charge isolation for two battery system.
5. Automatic fuel pump monitoring and backup fuel pump switching without using failure prone pressure switches.
6. Selection of engine start battery: select battery 1, battery 2 or both.
7. Emergency Power Switch function provides third level of Essential Bus protection.
8. Easy to mount 6” x 4” x 2.5” fan cooled enclosure.

The Bus Manager has been designed for durability. The circuits and internal heat sink have been thoroughly over designed to provide faithful service for many years. The Bus Manager has been designed to be thermally stable without the use of the included internal fan. The fan merely adds additional durability to an already rugged system.

Past system architectures have used a pressure switch or manual switch to turn on a back-up fuel pump in the case of primary pump failure. The Bus Manager monitors the signal that is available from the fuel pressure sender typically found in an engine monitor system. This is typically a VDO type pressure sender which have proven to be very reliable. The Bus Manager monitors the signal from this sender to determine if the primary fuel pump has degraded, and will automatically engage the backup fuel pump when necessary. This valuable function can be utilized to engage an electric backup pump when the primary pump is either mechanical or electric.

The Bus Manager contains all the necessary logic circuitry and relay connections internally. This makes for a very simple installation and hook up of the Bus Manager system in the vehicle.

Parts included in this kit

Qty	description
1	BMAN-1 Bus Manager control box
1	Bus Manager control harness
8	#10 x 10GA ring terminals
1	These instructions

Installation

Vehicle ground wiring

Grounding the vehicle systems

Proper operational of modern vehicle systems demands a good electrical grounding system on the vehicle.

The vehicle chassis or frame should never be considered to be an electrical path. The frame should be grounded at one point to the vehicle ground system. But other vehicle systems should not rely on a connection to the frame as a method of completing a circuit. All vehicle systems should have ground returns to a ground bus which is in turn connected to the battery ground with an appropriate gauge return wire.

The engine needs to have a large gauge ground wire connected to a secure bolt on the engine case or block. Never use a motor mount bolt as a ground cable connection point. Motor mount bolts experience a great deal of stress and movement and can be the source of a grounding problem if the engine ground is connected to them. The engine ground cable should be the same gauge wire that connects the main +12V power feed to the starter motor.

(refer to DRAWING 1)

If a ground bolt is used as a main ground pass through on the firewall, this is also a convenient place to tie in the ground bus which all vehicle systems will be grounded to.

The ground bus can be attached to the firewall ground bolt with a number 8GA wire.

Starter motor wiring

(refer to DRAWING 1) The starter motor can be powered by either or both batteries when using the Bus Manager. To use this feature, two starter solenoids are required.

These must be automotive type starter solenoids. Aircraft type master relays are wired differently internally and are not suitable for this purpose. The starter solenoids require a ground wire be connected to their mounting bracket to complete their internal circuit. Typically the starter solenoids would be mounted near the batteries to minimize the length of the large gauge wires that connect the solenoids to the batteries.

Complete the large gauge wiring for the engine grounding, starter power and solenoids as depicted on DRAWING 1.

Bus Manager Mounting

Find a mounting place for the Bus Manager in a convenient spot where it can be accessed later. Under the instrument panel where there is room available would be a typical location for mounting. The easiest mounting method for the Bus Manager is to use two 1/16" wall aluminum angles to cradle the bottom of the Bus Manager. Two large tie wraps can then be used to secure the Bus Manager into the angles. (see pics below).

Sample mounting using aluminum angle

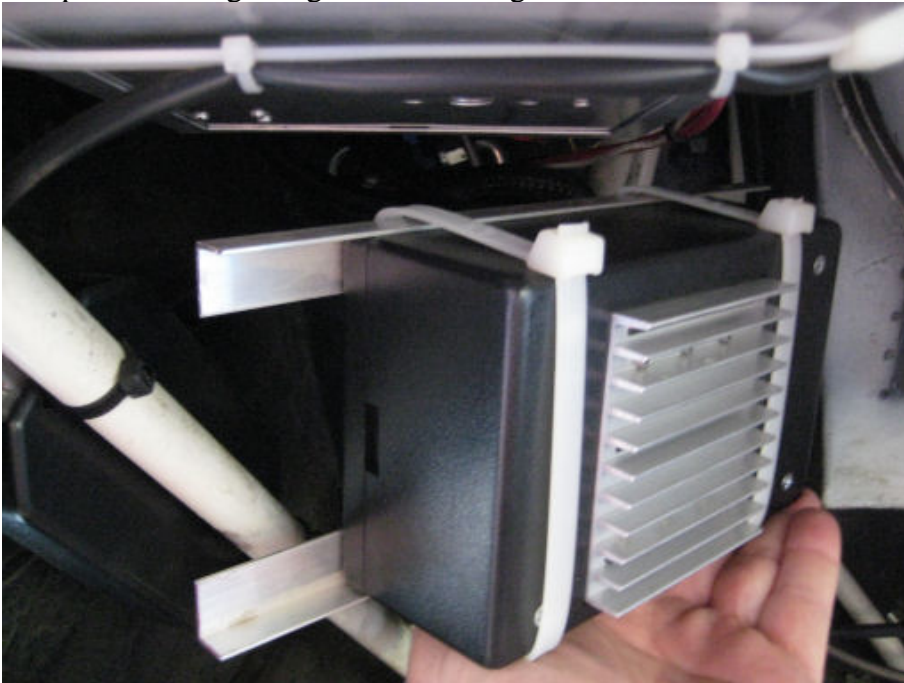

The Bus Manager from the outside

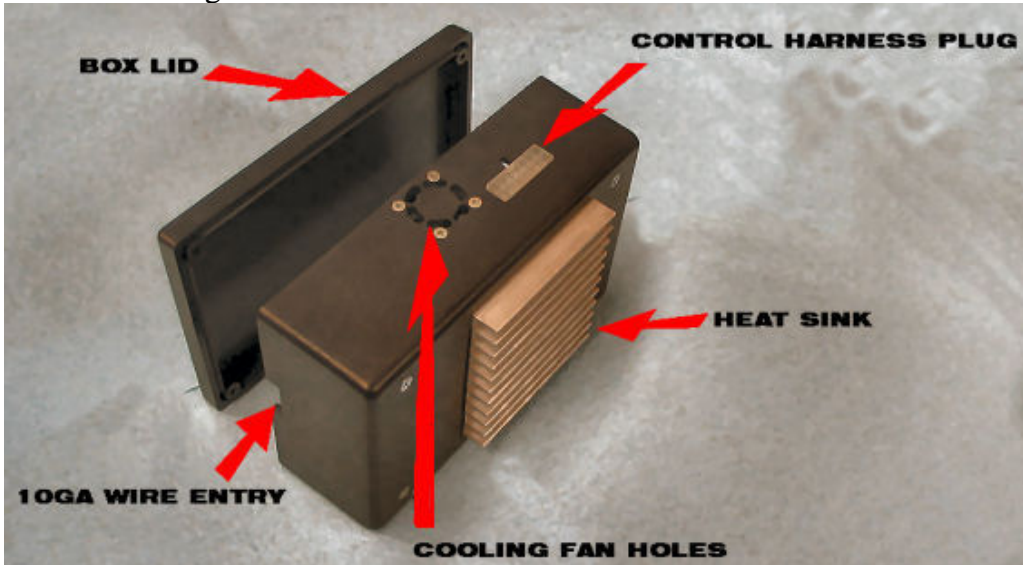

A look inside the Bus Manager

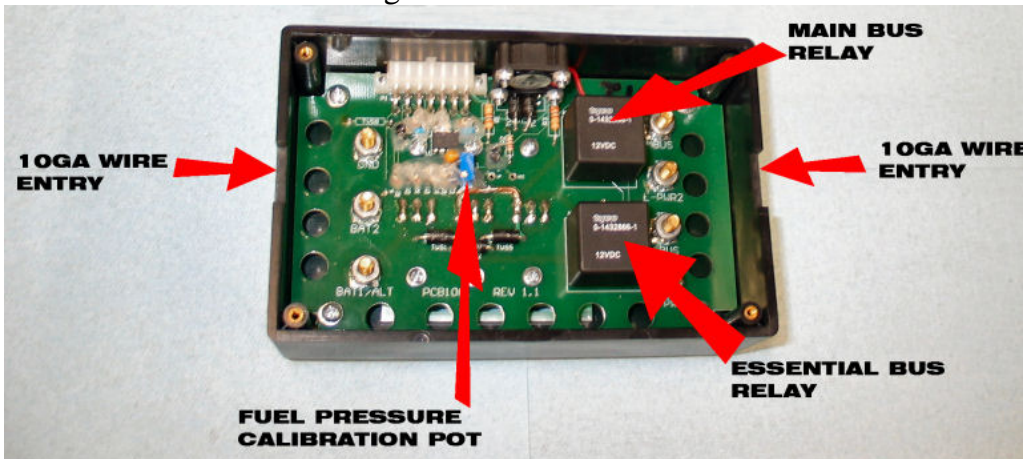

Note the cooling fan hole location on the side of the Bus Manager box as well as the heat sink on the box. Air should be able to freely get to the heat sink and fan holes. Do not mount either of these sides of the Bus Manager directly against other equipment. Also note the location of the control harness plug on the Side of the Bus Manager. This plug should be accessible at least during wiring.

After fabricating a mounting position, temporarily position the Bus Manager in place with tape so that it can be easily removed for installation of the system wires.

Bus Manager Bus Wiring

Wiring your Bus Manager system is very straight forward. Refer to DRAWING 2 and DRAWING 4.

Open the lid of the Bus Manager by removing the four small Phillips head screws located on the face of the Bus Manager that is OPPOSITE the heat sink. Inside you will see seven #10 screw terminals. These terminals will accept the 10GA wires required for the system as well as the 16GA Bus Manager ground wire. Use the included #10 crimp ring terminals to make your connections.

REFER to DRAWING 2

1. Connect a 10GA wire from the positive terminal of your primary battery (battery 1) to the Bus Manager terminal labeled BAT1/ALT.
2. As shown on DRAWING 2, run a 10GA wire from your alternator charging output post (usually a 1/4" screw post on the alternator) to a 60A alternator circuit breaker in your panel. Then run a 10GA wire from the 60A alternator breaker to the Bus Manager terminal labeled BAT1/ALT. (The same terminal that you connected to in the previous step).
3. Connect a 10GA wire from the positive terminal of your secondary battery (battery 2) to the Bus Manager terminal labeled BAT2.
4. The Bus Manager requires a 16GA ground wire as shown on DRAWING 2. This wire provides a ground connection for the control circuitry inside the Bus Manager. Connect the Bus Manager ground to the vehicle ground bus.
5. Locate the terminal in the Bus Manager labeled EBUS (may be labeled CBUS). This is the Essential Bus power output. This terminal will power all items critical to the running of the engine. This includes alternator field power, fuel pump power, ECU power, ignition power, and engine monitor power. The Essential Bus output is rated for a 30A max continuous load. These items should have breakers or switches where appropriate, grouped together in your panel layout. These "essential" items should be wired such that they receive their power from the EBUS (or CBUS) output of the Bus Manager. A convenient method of connecting items which are all powered from the same source is to arrange them in a linear fashion on your panel and screw a copper bar (or flattened piece of 1/4" diameter copper tubing across the devices. This would be referred to as "bussing" the items together. Using a 10GA wire, the Essential Bus power output of the Bus Manager can then be connected to this "Bus Bar". Make sure all bus screw connections use lock washers and are properly tightened.

6. Locate the terminal in the Bus Manager labeled MBUS. This is the Main Bus power output of the Bus Manager. This terminal will provide power for your other aircraft accessories, such as lights, radios, autopilot, trim, etc. The Main Bus power output is rated for 40A max continuous load. Items in your panel that will be powered by the Main Bus should be grouped in a linear fashion and tied together for power distribution with a bus bar as described in the previous section. Use a 10GA wire to connect the Main Bus output of the Bus Manager to the main bus bar.

7. The Bus Manager is equipped with an Emergency Power circuit which when used provides a third (triple redundant) electrical path to the Essential Bus. When activated, the Emergency Power switch bypasses the normal circuit path through the Bus Manager and directly connects the Essential Bus through a separate power circuit to the batteries. See DRAWING 5. The Emergency Power Switch should be connected as shown in DRAWING 4 to the E-PWR1 and E-PWR2 terminal within the Bus Manager. An ON/OFF switch of at least 30A max rating must be used for this purpose. Use 10GA wires to connect the Emergency Power Switch to the Bus Manager. Some people prefer to locate the Emergency Power Switch in a semi-hidden location, while others prefer it to be readily accessible on the panel. In either case, make sure it can easily be accessed while fully strapped into the vehicle.

Bus Manager Control Harness wiring

The Bus Manager control harness is a short harness in your kit with a 14 pin white connector. This harness provides signals to the Bus Manager for operation of the various control circuits. See DRAWING 2

A typical installation would include two mode switches, a start switch, and a key switch. The Start Battery Select Switch determines which battery (or batteries) start the vehicle engine. The Fuel Pump Mode Switch determines which fuel pump is running if a backup fuel pump is used. The Start Switch initiates engine cranking and the Key Switch turns on the system busses.

Start Battery Select Switch

This switch has three positions and is used to select whether the engine will be started using battery 1, battery 2, or both batteries when using two starter solenoids as shown on DRAWING 1. If the Start Battery Select Switch is not installed, and the start solenoids are installed as shown, the Bus Manager solenoid drive wires will always activate both solenoids during cranking and start the engine using both batteries. If using the Start Battery Select Switch, wire it to the control harness as shown on DRAWING 2.

Fuel Pump Mode Switch

This switch has two positions and determines the fuel pump drive operation of the Bus Manager. When in position “1/Auto” (the normal operating position), fuel pump 1 will be running and operating the engine. The Bus Manager will

continuously monitor the fuel rail pressure by tapping into the signal wire from the fuel pressure sender that is connected to your engine monitor. If the fuel rail pressure drops below a precalibrated limit, the bus Manager will automatically turn on fuel pump 2. When in position “2”, fuel pump 2 is forced on and fuel pump 1 will be turned off. Wire the Fuel Pump Mode Switch to the control harness as shown on DRAWING 2.

Start Switch

The Start Switch is a momentary switch (normally open or OFF), which when activated, will engage the starter motor and crank the engine. Wire the Start Switch to the control harness as shown in DRAWING 2.

Key Switch

The Key Switch is a key lock ON/OFF switch. When this switch is activated, the Bus Manager internal bus relays will be activated and the Essential Bus and Main Bus outputs of the Buss Manager will become hot. Wire the Key Switch to the control harness as shown in DRAWING 2.

Additional control harness wires

Starter Solenoid 1 drive (black wire)

This wire is used to activate Starter Solenoid 1 as shown on DRAWING 1. Connect as required using 16GA wire. NOTE – starter solenoid mounting bases must be grounded to complete their internal circuit.

Starter Solenoid 2 drive (red wire)

This wire is used to activate Starter Solenoid 2 as shown on DRAWING 1. Connect as required using 16GA wire. NOTE – starter solenoid mounting bases must be grounded to complete their internal circuit.

Fuel Pump Relay drive (grey wire)

This wire is used to activate the fuel pump relay as shown on DRAWING 3. If using the Bus Manager to manage a backup electric fuel pump, wire the pumps according to DRAWING 3, using a 10A circuit breaker to supply power to the fuel pump system.

Fuel Pressure Signal (purple wire)

This wire normally taps into the output wire of the fuel pressure sender that is part of your engine monitor system. The Bus Manager monitors the voltage on this wire to determine if you have normal fuel pressure. If the fuel pressure drops below a precalibrated limit, the Bus Manager will automatically activate the backup fuel pump (assuming you have configured you pumps according to DRAWING 3). Connect this wire to the signal output wire coming from your fuel pressure sender.

Using the Bus Manager

The Bus Manager is very simple to use. Once hooked up, it becomes a transparent part of the vehicle electrical system that requires little pilot input or monitoring.

The Start Battery Select Switch is generally left in one position – most people will leave it in the BOTH position and start the engine using both batteries. The exception to this might be if one battery is dead. Then the engine could be started off only the good battery so that the dead battery doesn't draw power from the system during cranking.

The Bus Manager will test all portions of the auto fuel pump backup circuit during start-up. Typically the Fuel Pump Mode Switch begins in the 1/AUTO position. As the key switch is turned on, the fuel pump backup circuit will instantly detect low fuel pressure since no pump had been running. This will cause the Bus Manager to automatically engage the backup fuel pump and it's associated annunciator lamp will come on. The pilot then resets the backup system by moving the Fuel Pump Mode Switch to PUMP 2 and then back to PUMP1/AUTO. This will reset the monitoring circuit and engage pump 1. This process tests all circuits and both pumps giving the pilot comfort in knowing that all aspects of the fuel system are operative.

The Start Switch is then used to start the engine normally.

The Main Bus and Essential Bus will become hot as soon as the Key Switch is turned on. Systems powered by the Main bus can be turned on at any time considered appropriate.

Calibrating the Auto Backup Fuel Pump Circuit

The Bus Manager can be calibrated to trigger the backup fuel pump at any desired fuel pressure. EFI systems typically have a fuel pressure regulator system that is compensated by manifold pressure. In other words, the fuel pressure will go up and down as manifold pressure goes up and down with application of throttle. It is desired to select a fuel pressure trip point for the Bus Manager that is below the normal operating range of fuel pressure. This will prevent the backup fuel pump from coming on when conditions are normal. It is common for the fuel pressure to vary by as much as 7 or 8 PSI during normal engine operation. If you activate one of the fuel pumps with the engine NOT running, this is your static fuel pressure. Subtract 10PSI from this pressure to determine a reasonable trip point for the backup fuel pump system. In other words, if your static fuel pressure (one pump ON and engine OFF) is 35PSI. Then a trip point of 25PSI would be reasonable to decide that there is a fuel pressure problem and that the secondary fuel pump should be engaged.

In order to set the fuel pressure at which the Bus Manager will engage the backup fuel pump, remove the Bus Manager cover (opposite the heat sink side of the box). You will see a rectangular trim pot in the middle of the circuit board as shown in DRAWING 4. There is a small screw on the top of the trim pot that is used to adjust the trip point of the backup fuel pressure system. If you turn the trim pot screw clockwise, the trip point pressure will go up. If you turn the trim pot screw counterclockwise, the trip point pressure will go down.

You will need to have your fuel system fully operative to test the trip point. If you find that the Bus Manager always activates pump 2 and will not reset to activate pump 1, then the trip point is too high and must be lowered. Once you have the trip point set so that pump 1 will remain on after a reset of the Fuel Pump Mode Switch (switch to PUMP 2 then back to PUMP 1/AUTO), you can then determine what pressure the backup system trips at by pinching off the fuel coming to your fuel pumps. This can usually be done with flat jaw vise grips or seaming pliers used to pinch down the fuel line feeding the pumps. Watch the fuel pressure as shown on your engine monitor. As you pinch the line, the fuel pressure will begin to drop and you can witness at what pressure the backup system engages pump 2. With a couple of adjustments, you should be able to calibrate the Bus Manager to activate pump 2 at the desired trip point pressure.

TYPICAL STARTER AND GROUND WIRING

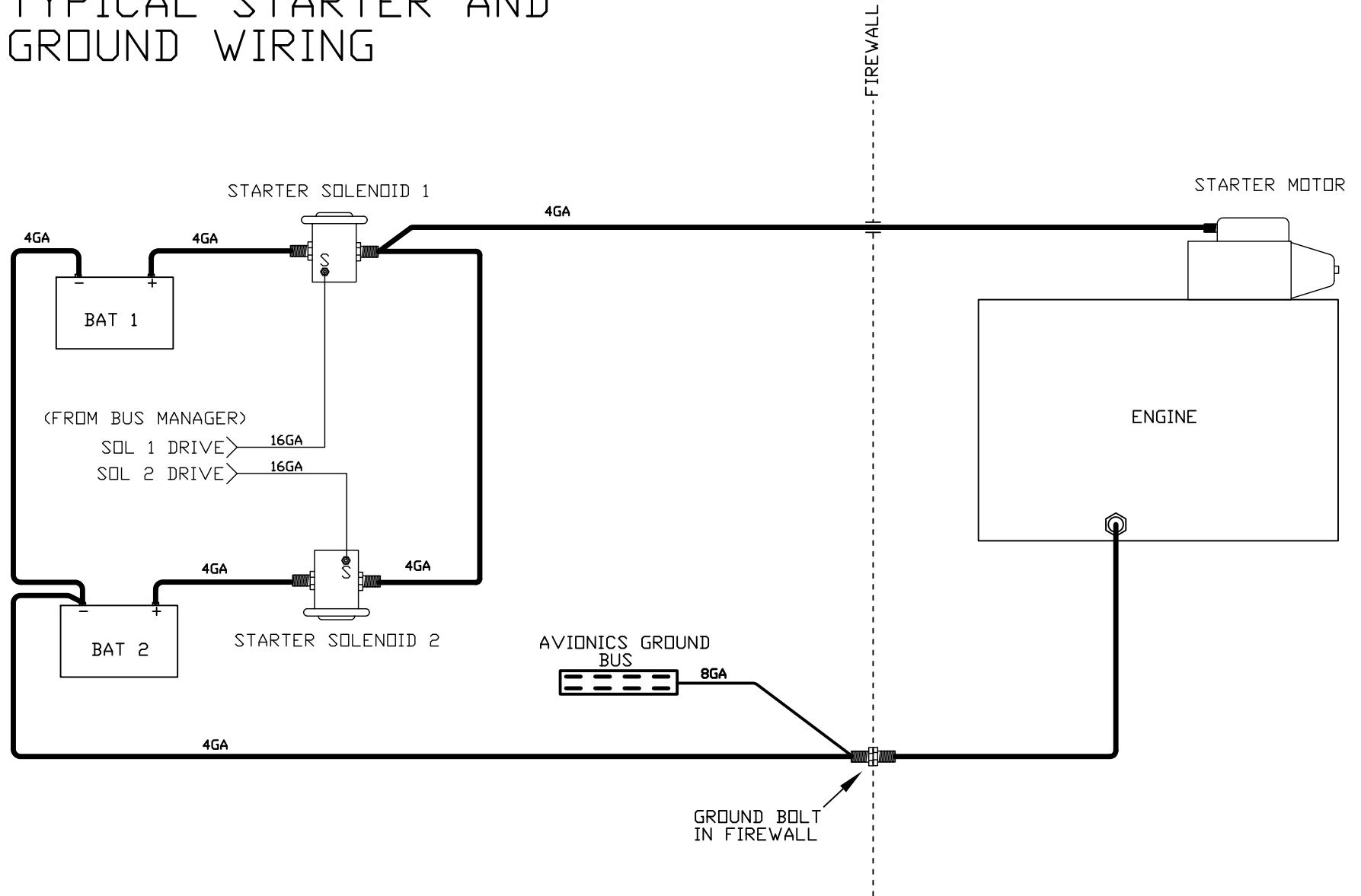

PROTEK PERFORMANCE <small>10393 Cartilla Ct., Alta Loma, CA 91737 951-317-3473</small>		
TITLE		CNC
BM starter wiring		
DATE	DRAWING NO.	REV
10-2-08	BM starter wiring.dwg	1.1

BUS MANAGER WIRING

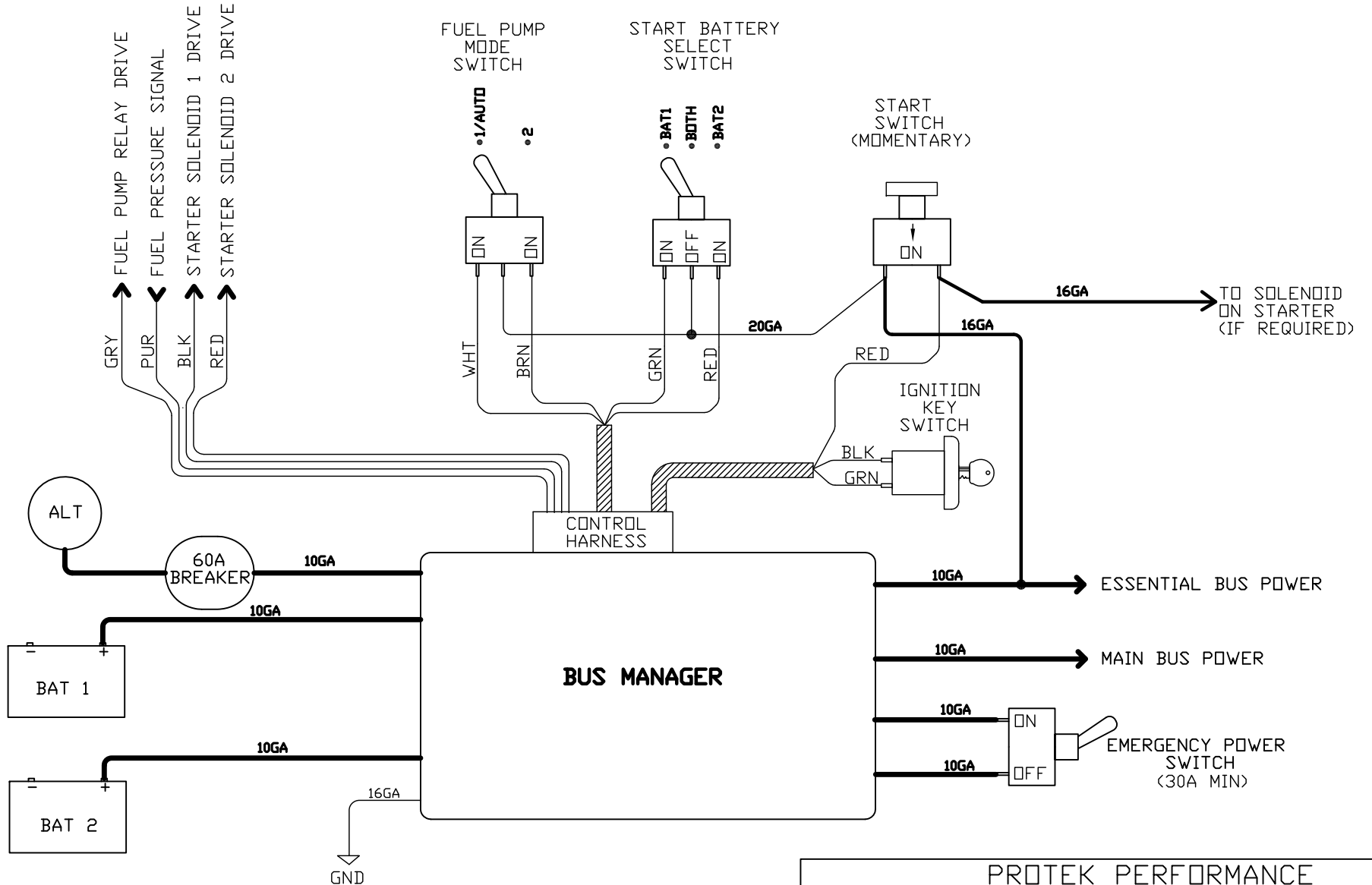

PROTEK PERFORMANCE		
<small>10393 Cartilla Ct., Alta Loma, CA 91737 951-317-3473</small>		
TITLE		CNC
BM wiring diagram		
DATE	DRAWING NO.	REV
4-14-10	BM wiring diagram.dwg	1.3

DRAWING 3

FUEL PUMP RELAY WIRING

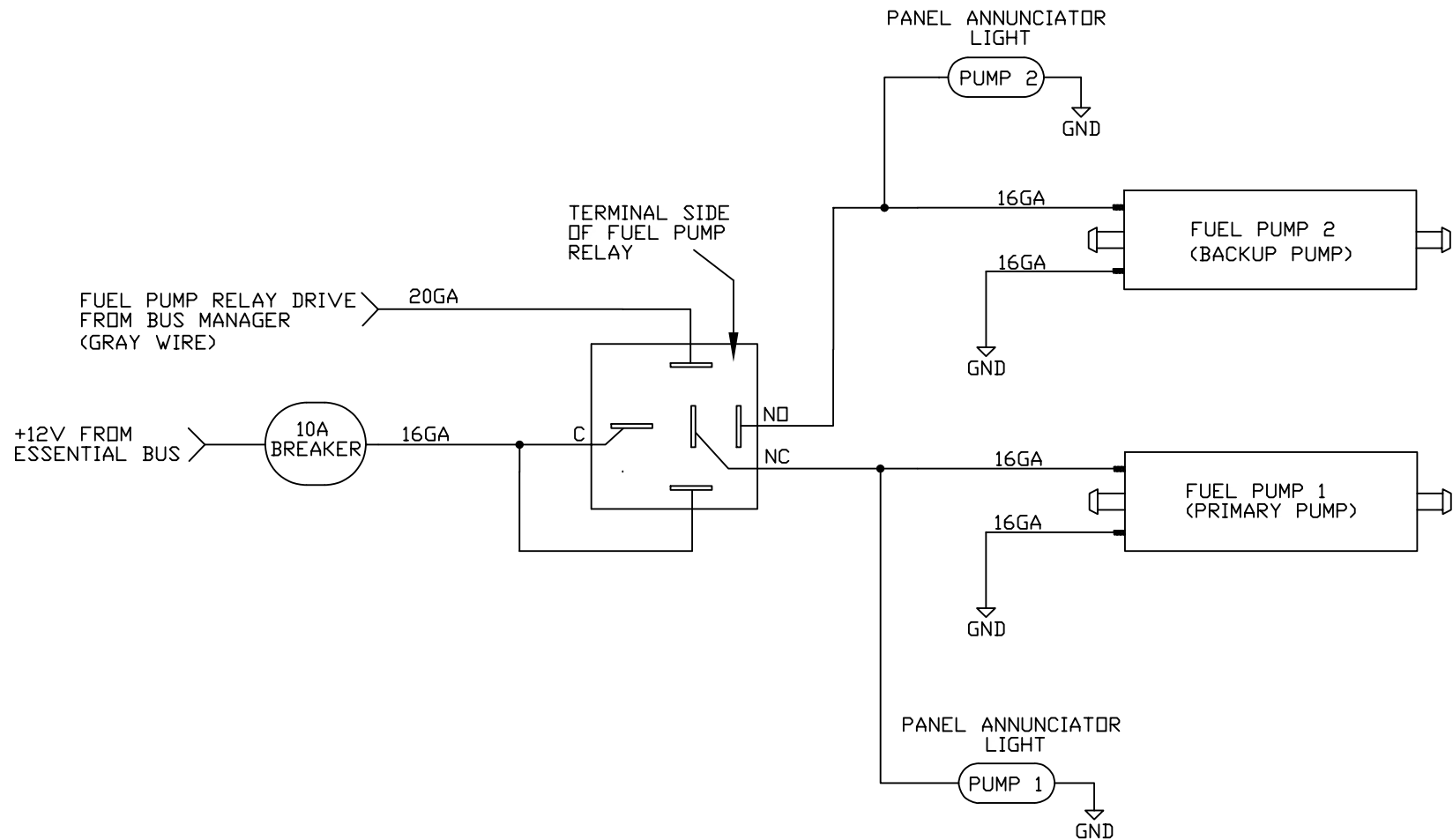

PROTEK PERFORMANCE <small>10393 Cartilla Ct., Alta Loma, CA 91737 951-317-3473</small>		
TITLE		CNC
BM fuel pump relay wiring		
DATE	DRAWING NO.	REV
10-22-08	BM fuel pump relay wiring.dwg	1.2

DRAWING 4

WIRE CONNECTIONS INSIDE BUS MANAGER

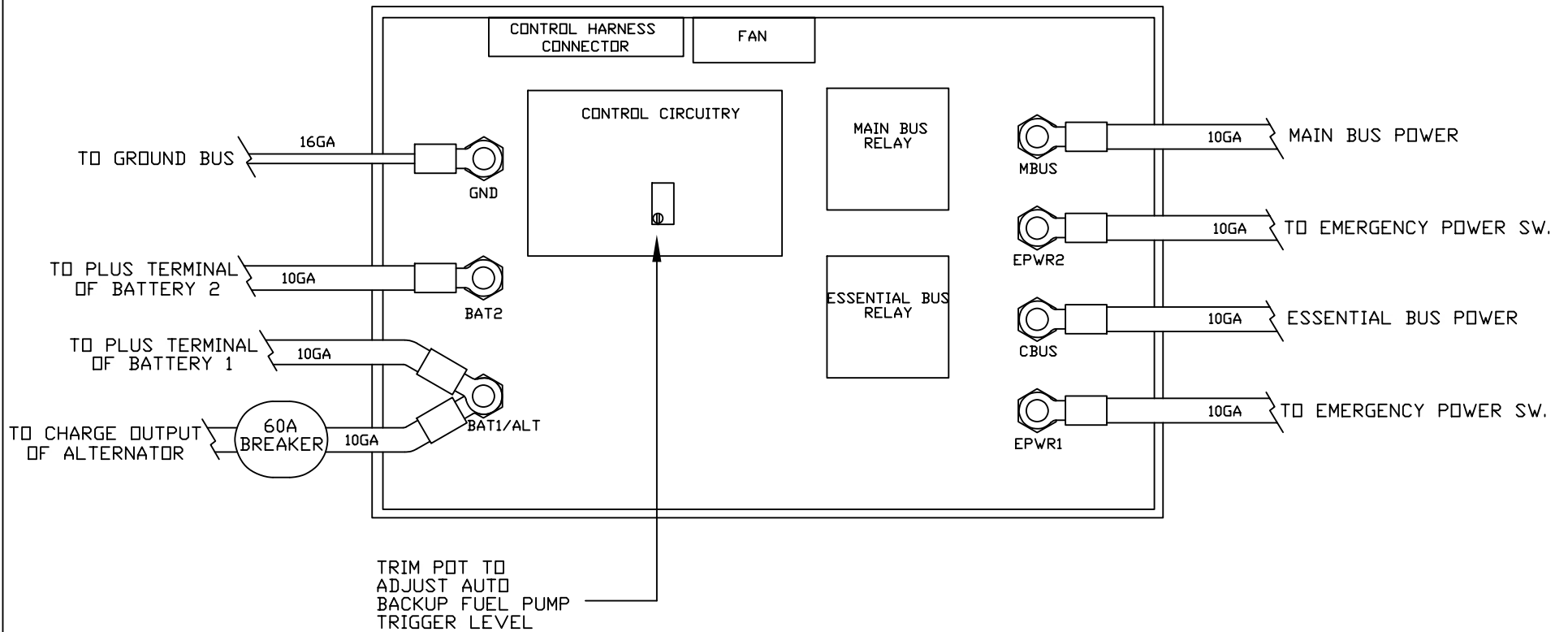

PROTEK PERFORMANCE 10393 Cartilla Ct., Alta Loma, CA 91737 951-317-3473		
TITLE		CNC
Bus Manager wire connections		
DATE	DRAWING NO.	REV
4-29-09	Bus Manager wire connections.dwg	1.1

POWER DISTRIBUTION DIAGRAM

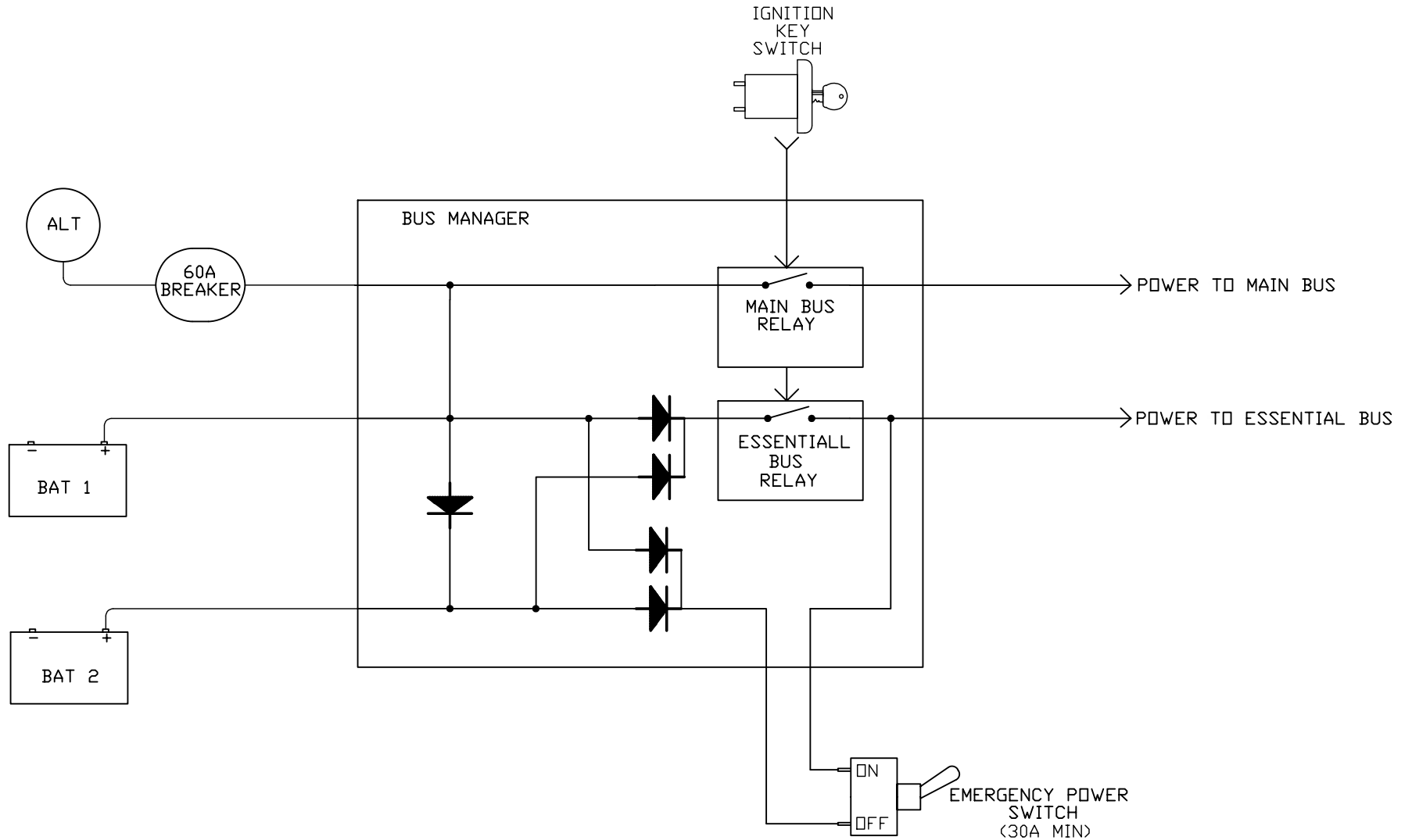

PROTEK PERFORMANCE <small>10393 Cartilla Ct., Alta Loma, CA 91737 951-317-3473</small>		
TITLE		CNC
Bus Manager power distribution diagram		
DATE	DRAWING NO.	REV
10-12-08	BM power distribution diagram.dwg	1.2

BUS MANAGER CONTROL HARNESS

DRAWING 6

AMP 1-794954-4
 DK#A30596
 TERMINAL DK#A30642
 WIRE SIDE SHOWN

8	1
9	2
10	3
11	4
12	5
13	6
14	7

AMP CONN.

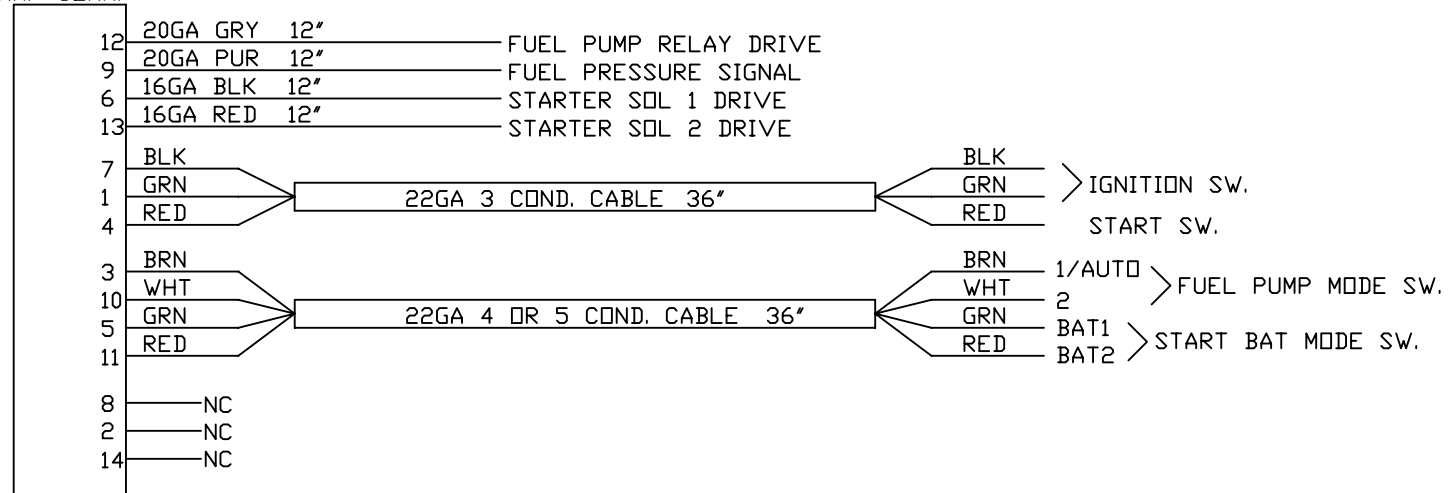

PROTEK PERFORMANCE <small>10393 Cartilla Ct., Alta Loma, CA 91737 951-317-3473</small>		
TITLE	BM control harness	CNC
DATE	DRAWING NO.	REV
10-2-08	BM control harness.dwg	1.1